

Weitergabe sowie Vervielfältigung dieser Unterlage, Verwertung und Mitteilung ihres Inhaltes nicht gestattet, soweit nicht ausdrücklich zugestanden. Zuwiderhandlungen verpflichten zu Schadensersatz. Alle Rechte für den Fall der Patentierung oder Gebrauchsmuster-Eintragung vorbehalten.
 This document is confidential and shall not be exploited, copied, re-printed or disclosed to a third party in any manner without our prior written permission. All rights reserved, especially in case of patent application or registration of petty patent.

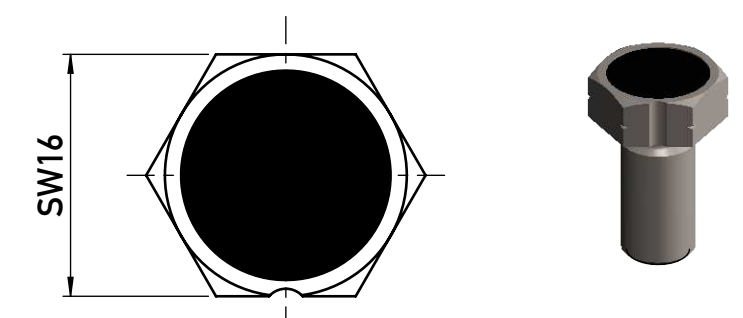
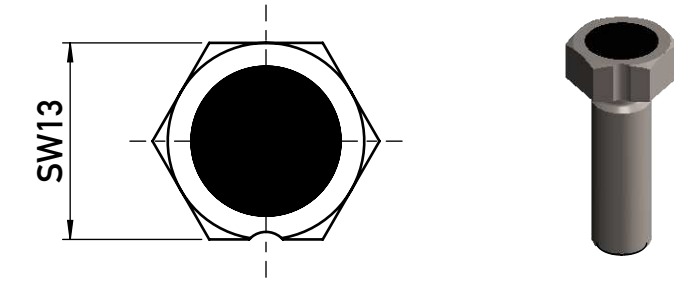
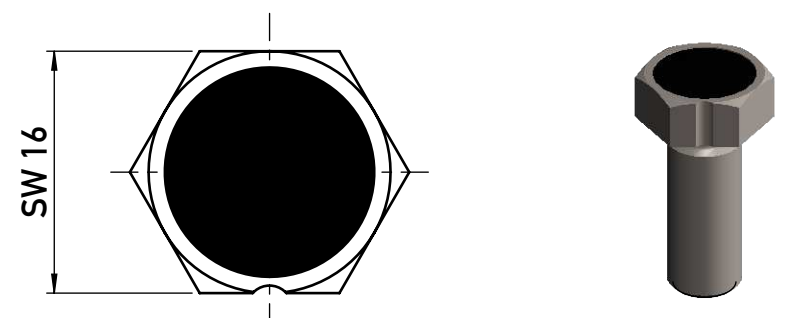
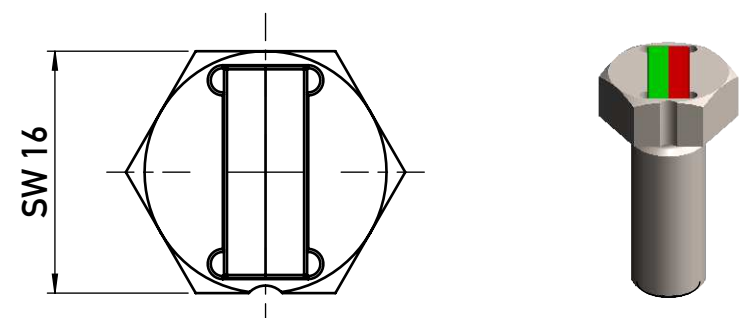
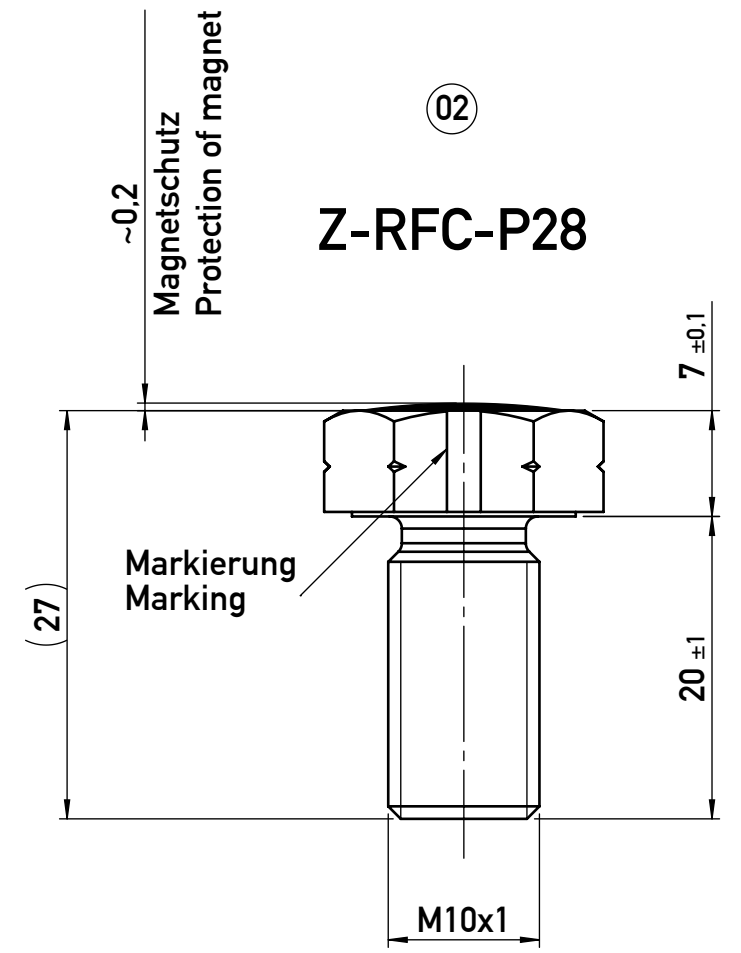
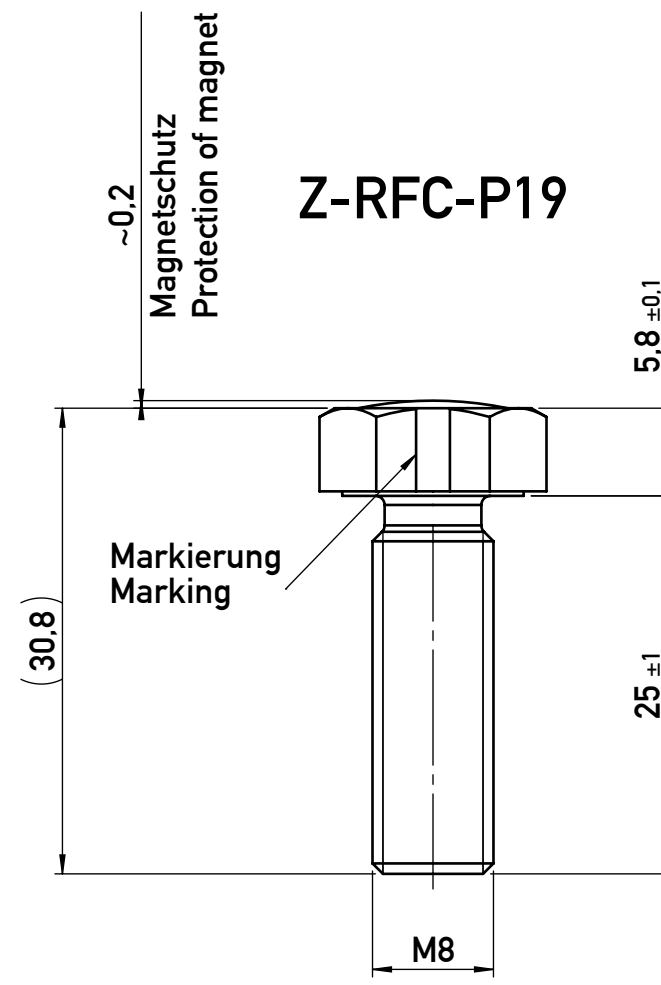
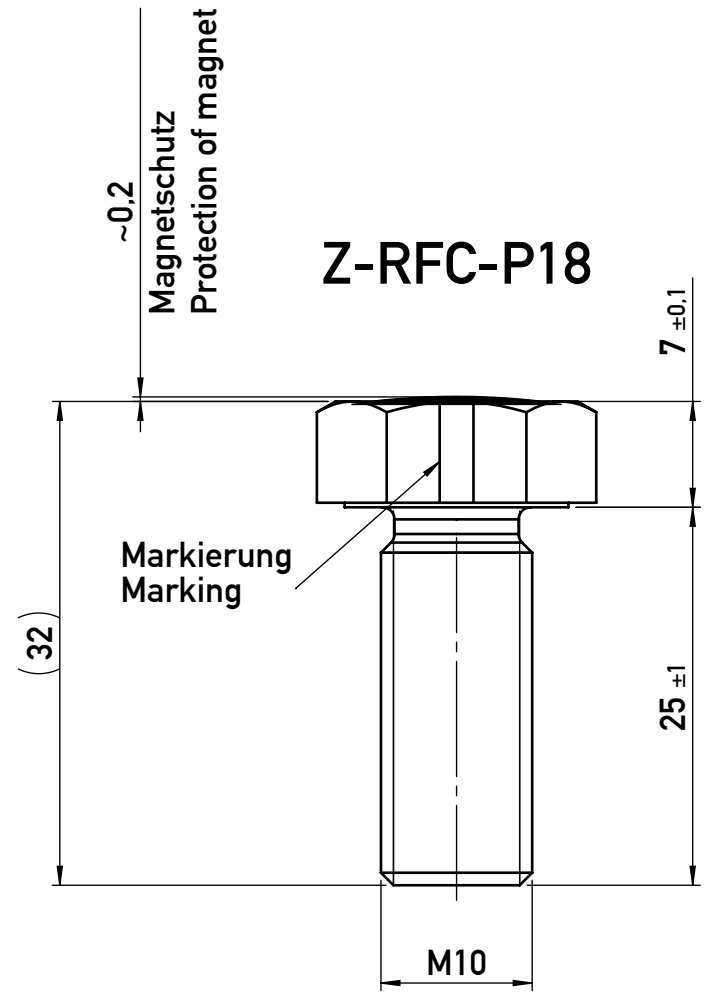
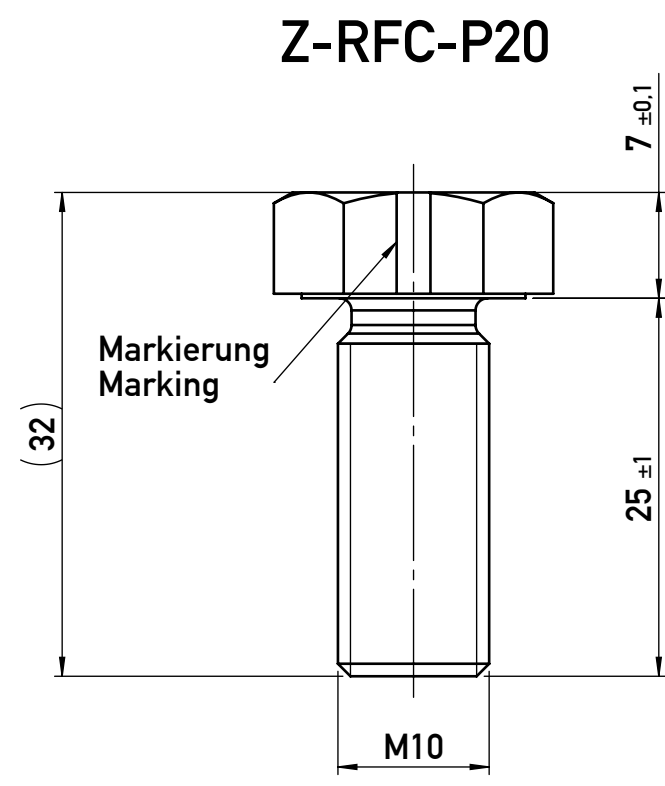

Mat. Nr. P/N	Typ Type
400104758	Z-RFC-P20
400104759	Z-RFC-P20-VPE025 (25 Stk / pcs)

Mat. Nr. P/N	Typ Type
400104756	Z-RFC-P18
400104757	Z-RFC-P18-VPE025 (25 Stk / pcs)

Mat. Nr. P/N	Typ Type
400104754	Z-RFC-P19
400104755	Z-RFC-P19-VPE025 (25 Stk / pcs)

Mat. Nr. P/N	Typ Type
400108462	Z-RFC-P28
400108463	Z-RFC-P28-VPE025 (25 Stk / pcs)

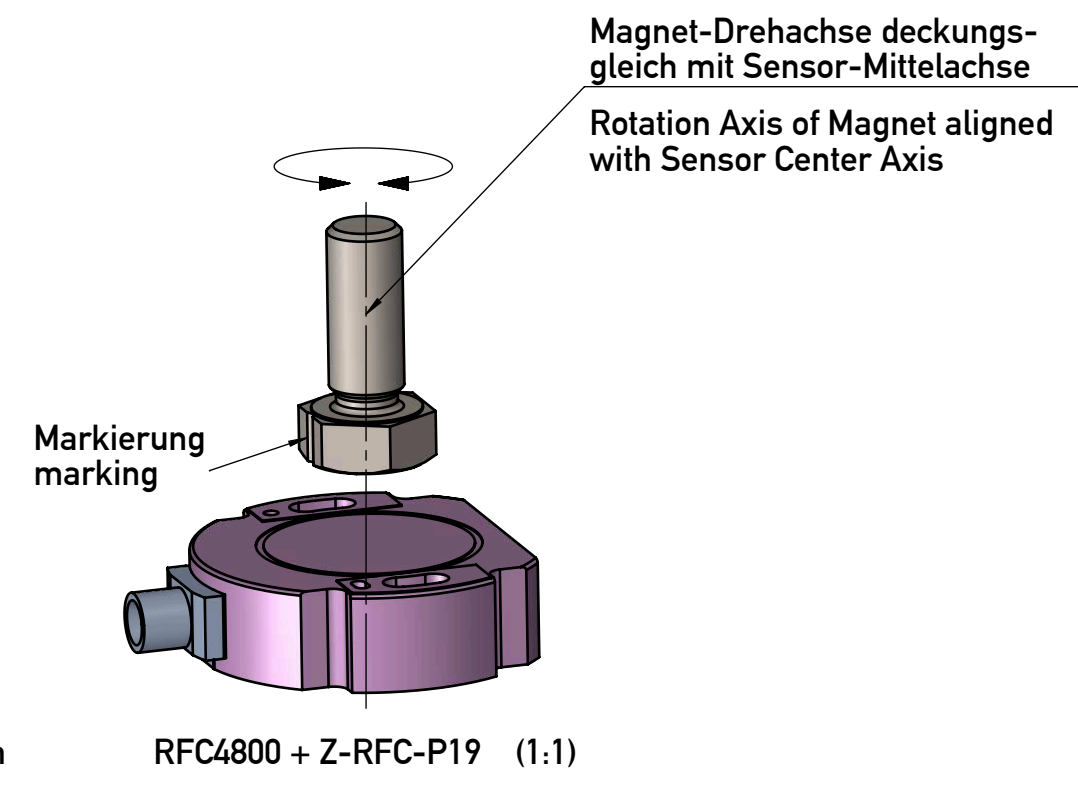

Indexposition Index position
 RFC4800 + Z-RFC-P19 (1:1)

Montagehinweise und Arbeitsabstände siehe Montageanleitung
 Installation instructions and operating distances see manual

Status: freigegeben / released				geltende Dokumente regarding documents	
Version	Änd.-Nr. revision no.	Änderung revision description		Datum / date Bearbeitet / drawn by	Datum / date Geprüft / approved by
02	422-0052	P28 hinzu		12.07.2022 Thiel	10.01.2023 Schlecht
Form- u. Lagertoleranzen nach shape and position tolerance per		Nichttol. Maße unspecified tolerances		Tolerierungsprinzip tolerancing principle	
-		-		ISO 8015	
Oberflächenangaben nach surface tolerancing per		ECE (KBA) ECE (KBA)		Gewicht / weight	
-		Nein/No		-	
Werkstückkanten nach part edges per		FuSi functional safety		Werkstoff / material	
-		Nein/No		Aluminium eloxiert / anodized	
Projektionsmethode 1 projection method 1		Benennung / title		Format size	
-		Z-RFC-P18/P19/P20/P28		A2	
-		-		Maßstab scale	
-		-		2:1	
-		-		Material-Nr. material no.	
-		-		siehe Auflistung	
-		-		Dokument-Nr. / document no.	
-		-		900076997	
-		-		Teil-Nr. / document part	
-		-		001	
-		-		Blatt / sheet	
-		-		1	